



MILAN WALL

SETUP GUIDE

MILAN WALL SETUP



Snap Button Connector



Baseplate Installation

1. Components for each tension fabric structure should be laid out separately or one at a time.
2. Assemble frame and apply fabric on either a clean surface or on a drop cloth. Use white gloves to keep dirt and fingerprints away from fabric.
3. Milan Wall frames are assembled by matching identically numbered joints, indicated by blue balloons on following page(s), inserting tube ends into sleeves, and snapping together with Snap Button Connectors. Be sure that each Snap Button is fully engaged in matching hole for a secure connection.
4. Working from the top downward, gently pull tension fabric sleeve over frame. Zip closed along bottom seam. Adjust fabric by pulling and twisting around the tubes for best fit.
5. To install baseplate, insert spigot on baseplate into tube end at bottom of frame, insert locking pin, and snap retaining band over end of pin. See illustration above.
6. Where applicable, carefully hook curved clip at top of Stand-Off Frame over top of Vertical Curved Milan Wall.

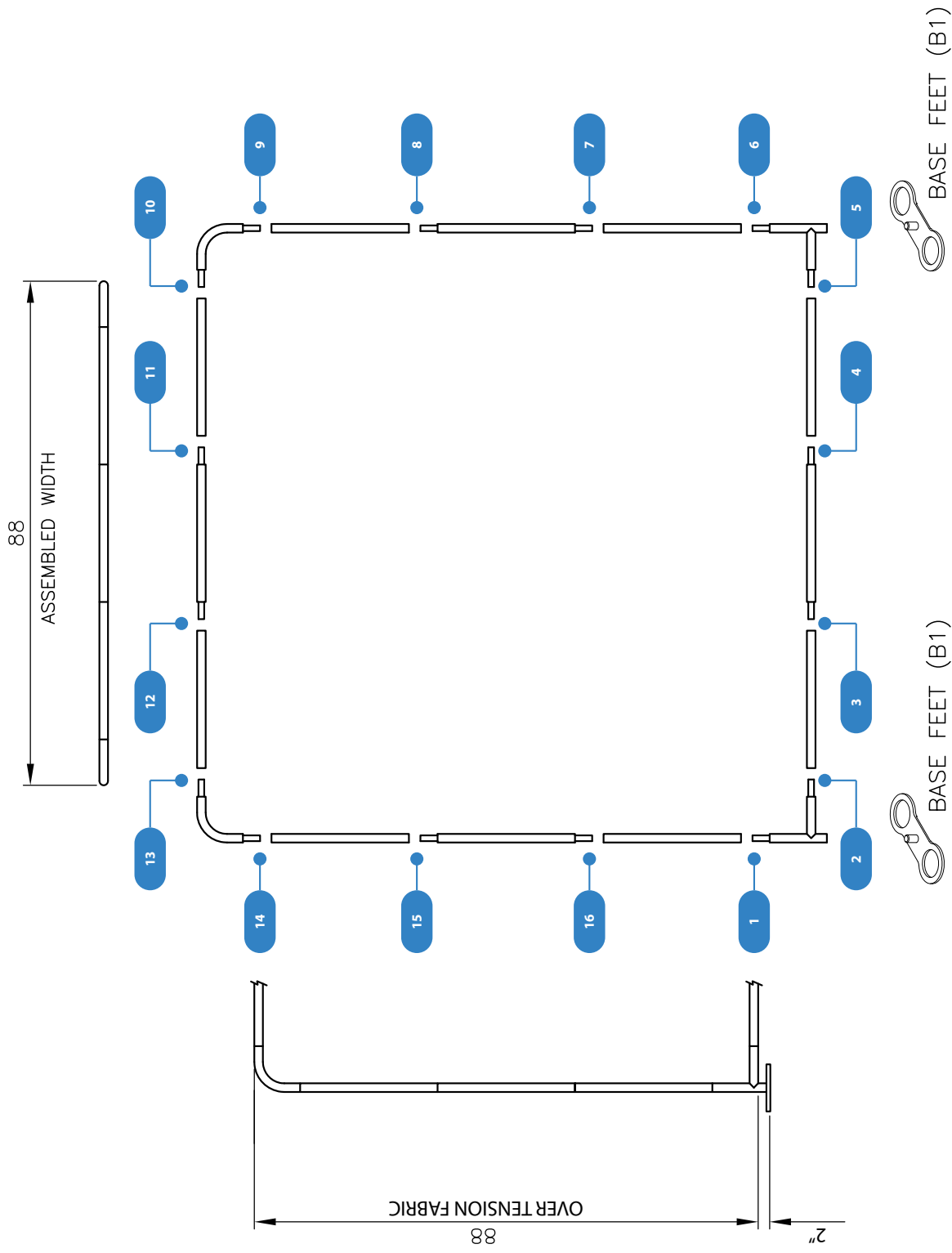

Frame Nominal Dimensions: 88" x 90"

MILAN WALL STRAIGHT 88" x 88"

24/7 Assistance 1.800.663.1737

www.xibita.com

www.theportables.com

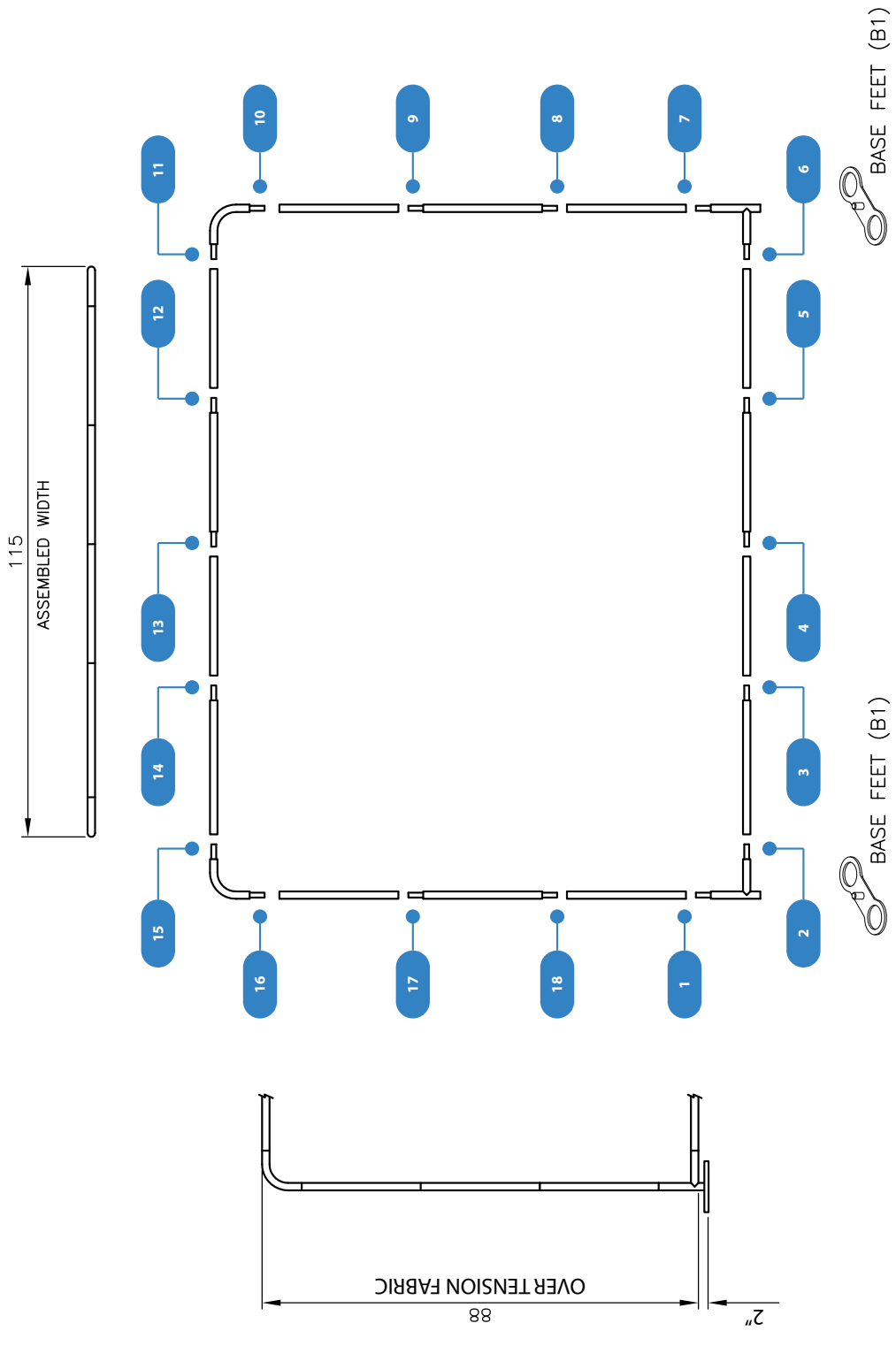

Frame Nominal Dimensions: 115" x 90"

MILAN WALL STRAIGHT 115" x 88"

24/7 Assistance 1.800.663.1737

www.xibita.com

www.theportables.com

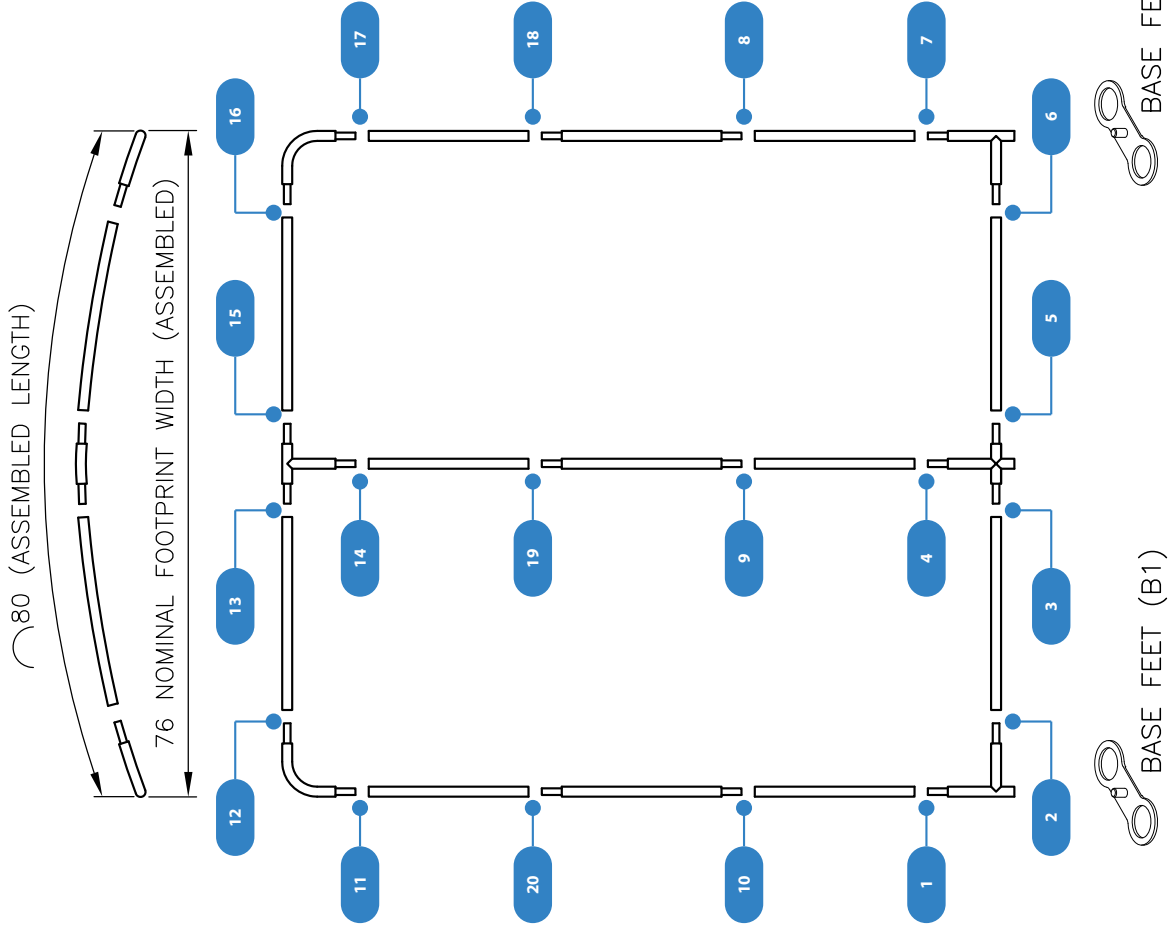

MILAN WALL HORIZONTAL CURVE 80" x 88"

Frame Nominal Dimensions: 76" x 90"

24/7 Assistance 1.800.663.1737

www.xibita.com

www.theportables.com

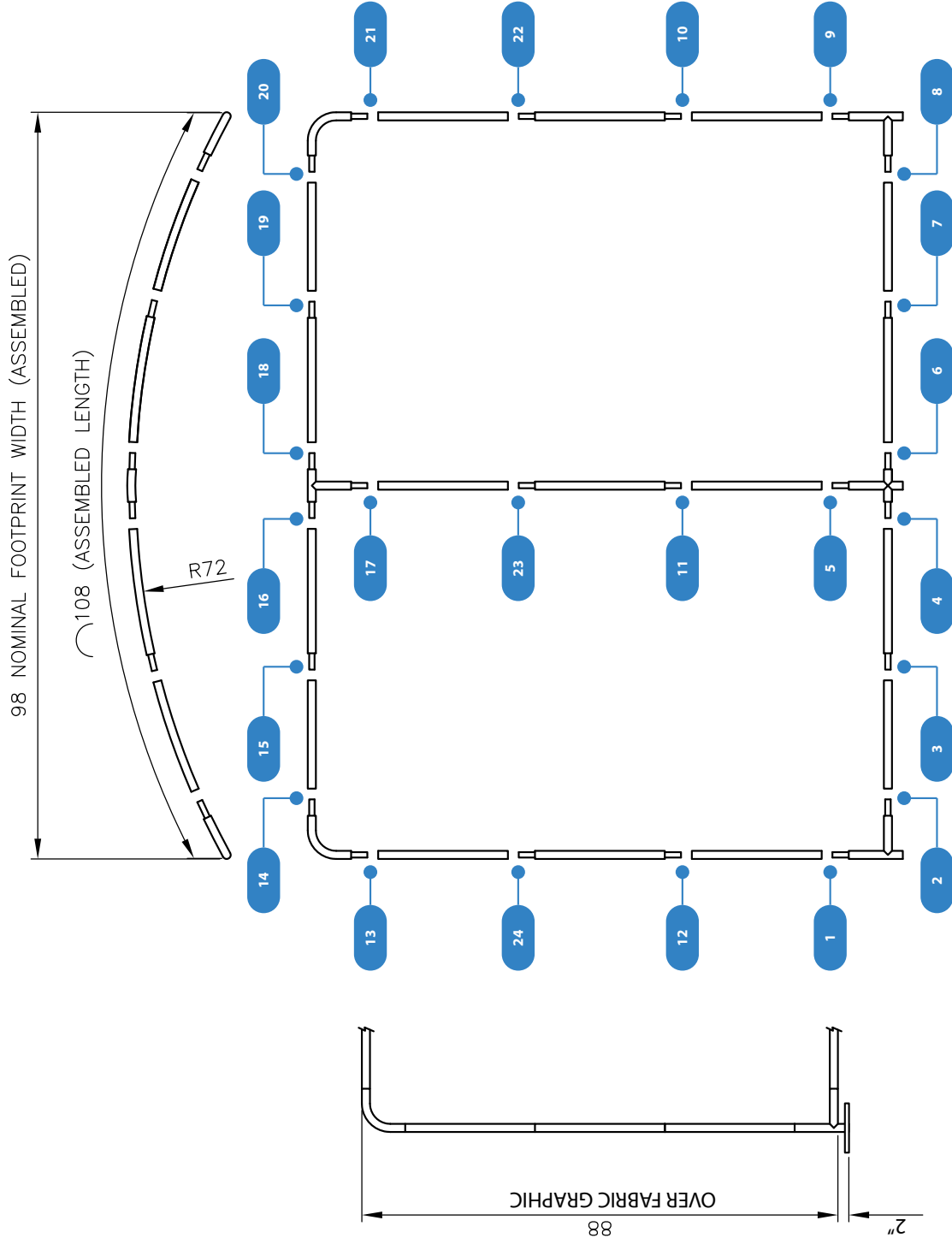

Frame Nominal Dimensions: 98" x 90"

MILAN WALL HORIZONTAL CURVE 108" x 88"

24/7 Assistance 1.800.663.1737

www.xibita.com

www.theportables.com

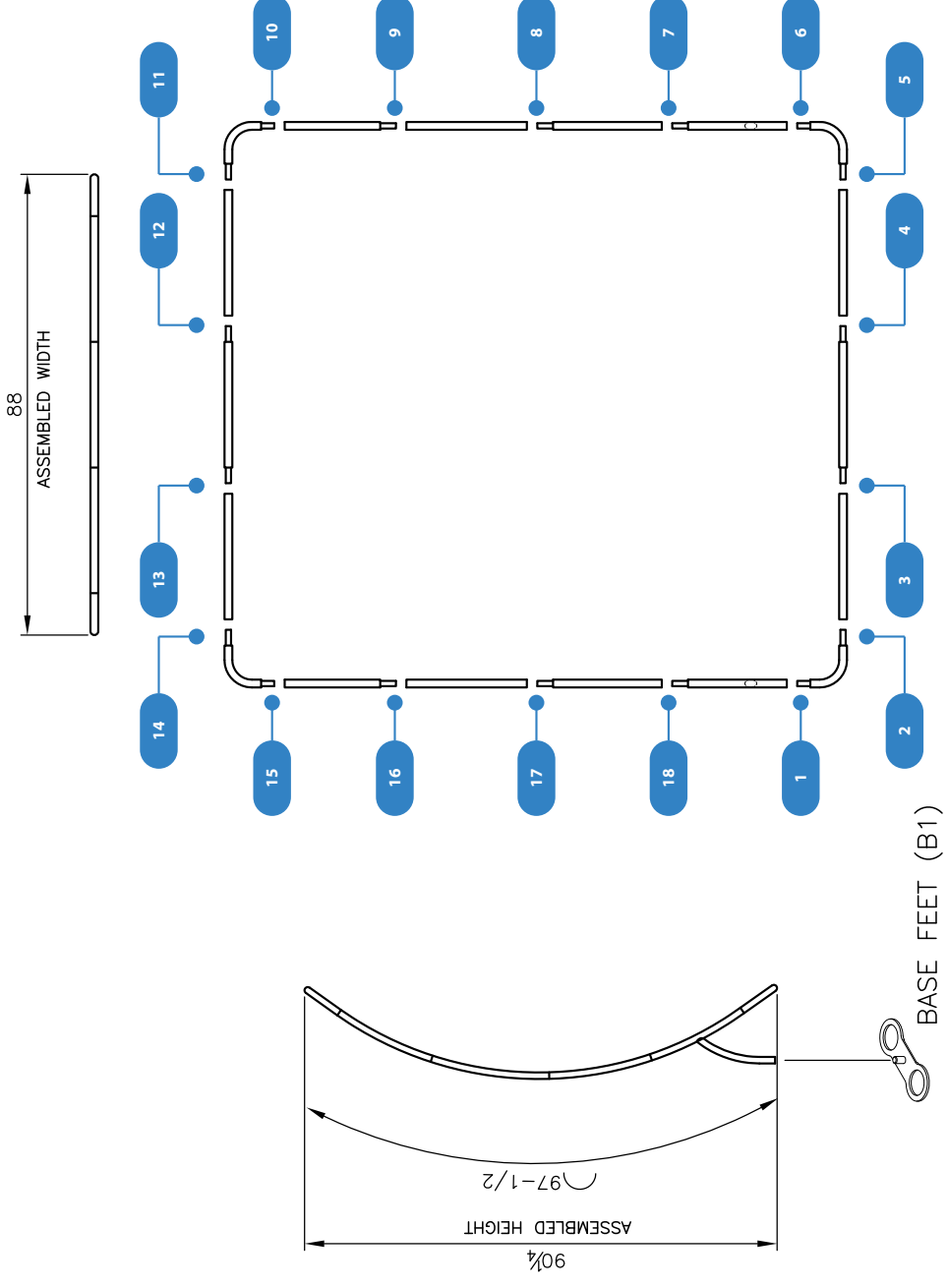

Frame Nominal Dimensions: 88" x 90"

MILAN WALL VERTICAL CURVE 88" x 97.5"

24/7 Assistance 1.800.663.1737

www.xibita.com

www.theportables.com

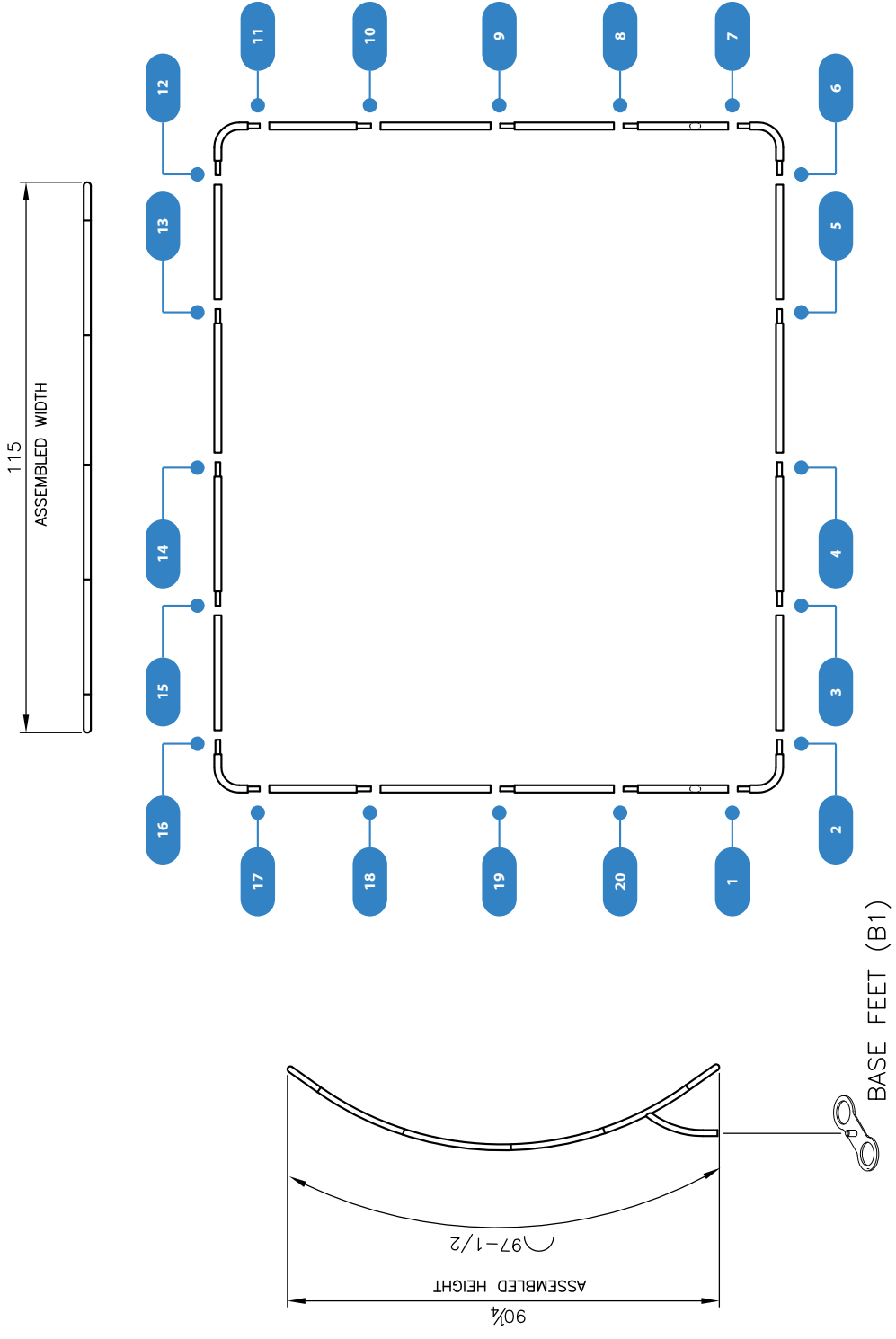

Frame Nominal Dimensions: 115" x 90"

MILAN WALL VERTICAL CURVE 115" x 97.5"

24/7 Assistance 1.800.663.1737

www.xibita.com

www.theportables.com

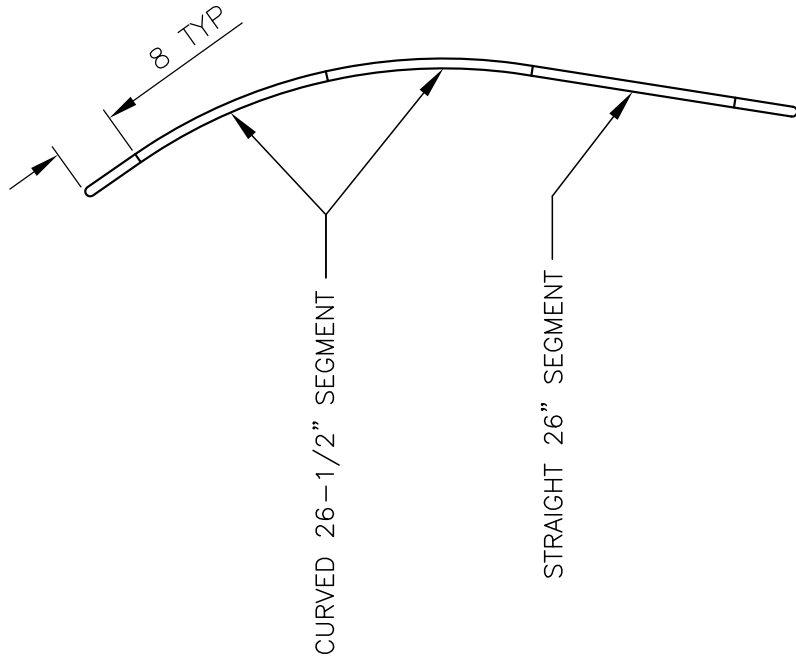
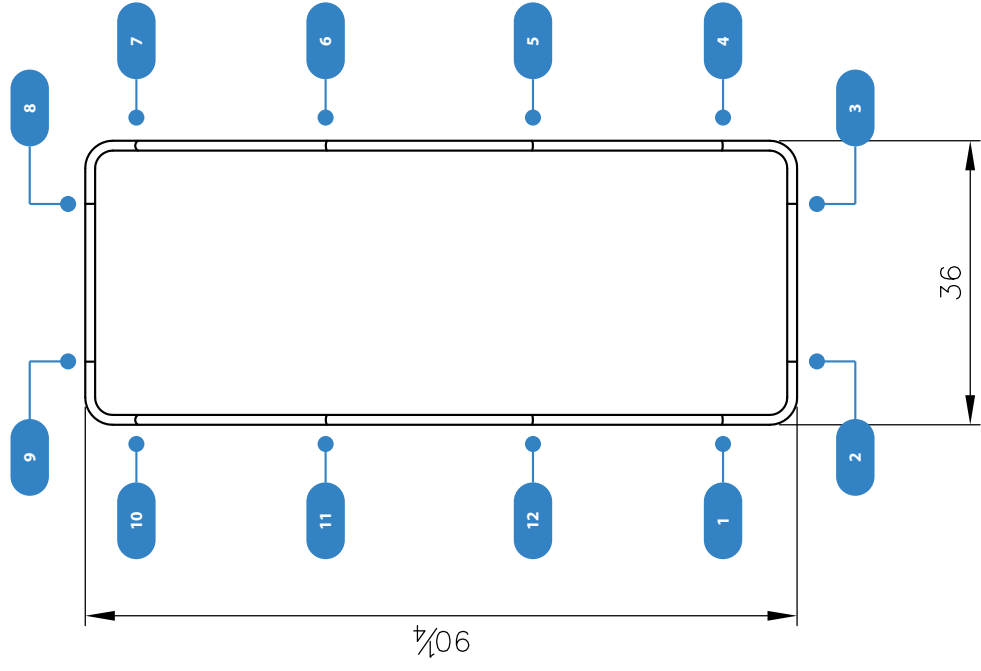

Frame Nominal Dimensions: 36" x 90"

MILAN WALL STAND-OFF FRAME 36" x 95"

24/7 Assistance 1.800.663.1737

www.xibita.com

www.theportables.com

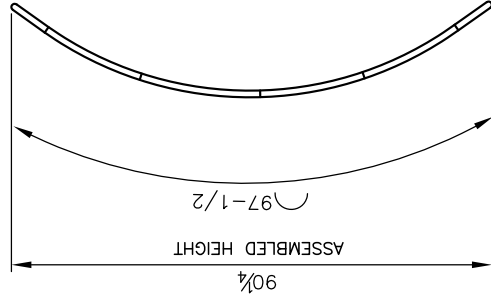
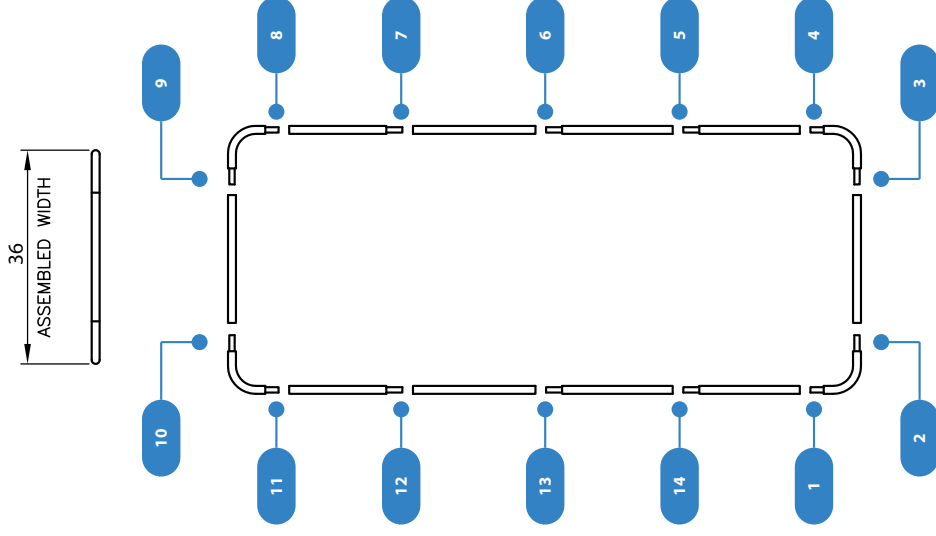

Nominal Frame Dimensions: 36" x 90"

MILAN WALL BOW FRAME 36" x 97.5"

24/7 Assistance 1.800.663.1737

www.xibita.com

www.theportables.com

TENSION FABRIC INSTRUCTIONS

TENSION FABRIC CARE INSTRUCTIONS

FABRIC SPOT CLEANING –DRY METHODS

- To remove loose dust, brush gently with a white terry cloth towel or soft nylon brush.
- For light dirt stains, gently rub affected area with a white art eraser such as *Staedtler Mars Plastic*.
- Use *clean* compressed air to remove statically attracted dust. **Caution:** some compressors may deliver air containing moisture or misted lubricants which can discolor fabric.

FABRIC SPOT CLEANING –WET METHODS

- To spot clean stubborn dirt stains, use water with a mild, colorless detergent such as Ivory liquid dish washing soap applied to a clean terry cloth or soft-bristled toothbrush. Rub lightly in a circular motion with a clean white cloth held behind the fabric. Rinse soap completely out of fabric and tamp with a dry white cloth.
- For more intense stains, use equal parts hydrogen peroxide and Ivory liquid dish soap applied to a single thickness of fabric. Rub lightly as above. Rinse with a clean white cloth and water.
- **Caution:** Some fabrics may spot when cleaning regardless of substance applied, including water. Always test wet cleaning methods first on a small, non-critical area.

LAUNDERING FABRIC

- Most tension fabric may be laundered. (See Cautions below.) Machine wash in cold water and partially cool air dry in dryer.
- Wash white and differently colored fabrics separately.
- *Never* use hot or warm washing or drying cycles or shrinkage may result.
- Remove partially dried cover and install over frame to finish drying. This will help prevent shrinkage and retain the shape of fabric covers.
- Do not steam or iron tension fabric.
- Ensure that fabric is completely dry before packing.
- **Caution:** Do not dry clean tension fabric. Dry cleaning may damage dye-sub printed fabric and remove fire retardant coatings.
- **Caution:** Covers incorporating a light blocker, i.e. two layers of fabric sewn together, may not be laundered. Use mechanical cleaning methods only.
- **Caution:** The Portables/Xibita assumes no liability for damage incurred as a result of cleaning fabric.

FRAME CLEANING

- Frame may be cleaned using warm, sudsy water. Using a soft, non-abrasive cloth, rub against the grain of the aluminum to remove dirt and tarnish.
- Dry immediately with a soft non-abrasive cloth.
- Do not apply spray or other lubricants to frame joints as these may stain fabric.

ASSEMBLY CARE

- Most tension fabric structures assemble simply by matching numbered joints and joining Snap Button Connectors or with the occasional use of an Allen key. Refrain from applying excessive force or from using tools not specified in the assembly instructions such as screwdrivers, wrenches, or hammers, as these may damage frames.
- For ease of assembly, where frame sections have multiple connections, generally insert all tube ferrules into mating tube ends before fully engaging Snap Buttons.
- Always use all possible care to keep fabric covers clean. The best way to extend the useful lifespan of your tension fabric display is to keep it clean so as to reduce the need for cleaning or laundering.
- Assemble tension fabric display structures and apply covers on a clean drop cloth.
- Whenever possible, use white gloves when handling fabric. Otherwise wash and dry hands thoroughly before handling fabric.
- When applying fabric over frames, gently tug into place so that fabric is taut and smooth. Where possible, handle fabric at seams or zippers along frames. Avoid grabbing or crumpling fabric graphic fields.

PACKING AND STORAGE

- Frames and fabric covers should be stowed and hand-carried in the original storage bags provided.
- Avoid stacking heavy items on top of tension fabric bags.
- For shipping, pack tension fabric bags inside corrugated shipping boxes or crates for protection. Tension fabric bags should not be shipped loose.
- Store tension fabric displays in a cool, dry environment, 7° to 24°C (45° to 75°F). Avoid prolonged exposure to excessive temperatures or humidity.